

Corrosion resistant/Dacromet-plated chains

达克罗链条适合于有腐蚀性的场合

Dacromet-plated chains are suitable for corrosive conditions

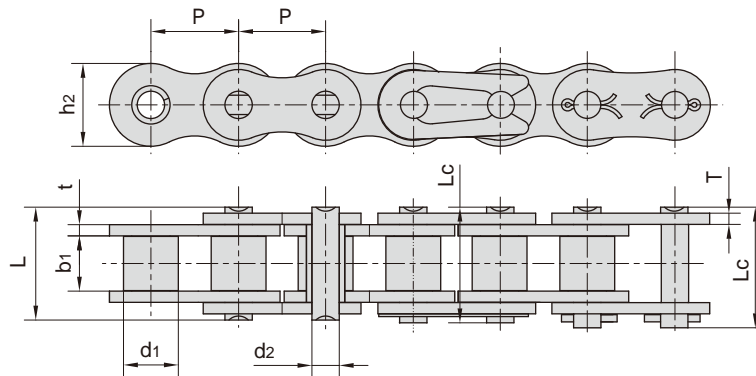

东华链号 Donghua Chain No.	节距 Pitch	滚子直径 Roller diameter	内节内宽 Width between inner plates	销轴直径 Pin diameter	销轴长度 Pin length		内链板高度 Inner plate depth	链板厚度 Plate thickness	破断载荷 Breaking load	每米长重 Weight per meter
	P	d1 max	b1 min	d2 max	L max	Lc max	h2 max	t/T max	Q	q
	mm	mm	mm	mm	mm	mm	mm	mm	kN/lbf	kg/m
*25DR	6.350	3.30	3.18	2.31	7.90	8.40	6.00	0.80	3.50/795	0.15
*35DR	9.525	5.08	4.77	3.58	12.40	13.17	9.00	1.30	7.90/1795	0.33
41DR	12.700	7.77	6.25	3.58	13.75	15.00	9.91	1.30	6.67/1516	0.41
40DR	12.700	7.95	7.85	3.96	16.60	17.80	12.00	1.50	14.10/3205	0.62
50DR	15.875	10.16	9.40	5.08	20.70	22.20	15.09	2.03	22.20/5045	1.02
60DR	19.050	11.91	12.57	5.94	25.90	27.70	18.00	2.42	31.80/7227	1.50
80DR	25.400	15.88	15.75	7.92	32.70	35.00	24.00	3.25	56.70/12886	2.60
100DR	31.750	19.05	18.90	9.53	40.40	44.70	30.00	4.00	88.50/20114	3.91
120DR	38.100	22.23	25.22	11.10	50.30	54.30	35.70	4.80	127.00/28864	5.62
140DR	44.450	25.40	25.22	12.70	54.40	59.00	41.00	5.60	172.40/39182	7.50
160DR	50.800	28.58	31.55	14.27	64.80	69.60	47.80	6.40	226.80/51545	10.10
04BDR	6.000	4.00	2.80	1.85	6.80	7.80	5.00	0.60	3.00/682	0.11
05BDR	8.000	5.00	3.00	2.31	8.20	8.90	7.10	0.80	5.00/1136	0.20
#06BDR	9.525	6.35	5.72	3.28	13.15	14.10	8.20	1.30	9.00/2045	0.41
08BDR	12.700	8.51	7.75	4.45	16.70	18.20	11.80	1.60	18.00/4091	0.69
10BDR	15.875	10.16	9.65	5.08	19.50	20.90	14.70	1.70	22.40/5091	0.93
12BDR	19.050	12.07	11.68	5.72	22.50	24.20	16.00	1.85	29.00/6591	1.15
16BDR	25.400	15.88	17.02	8.28	36.10	37.40	21.00	4.15/3.1	60.00/13636	2.71
20BDR	31.750	19.05	19.56	10.19	41.30	45.00	26.40	4.5/3.5	95.00/21591	3.70
24BDR	38.100	25.40	25.40	14.63	53.40	57.80	33.20	6.0/4.8	160.00/36364	7.10
28BDR	44.450	27.94	30.99	15.90	65.10	69.50	36.70	7.5/6.0	200.00/45455	8.50
32BDR	50.800	29.21	30.99	17.81	66.00	71.00	42.00	7.0/6.0	250.00/56818	10.25

*套筒链：表中滚子直径d1为套筒直径

*Bush chain: d1 in the table indicates the external diameter of the bush

#直链板

#Straight side plates

注意：上述规格的双排链和叁排链、双节距输送链系列依照要求也适合镀达克罗

Note: Duplex & Triplex dacromet - plated chains are available in all sizes

Double pitch dacromet - plated conveyor chains are available upon request