

C a a a

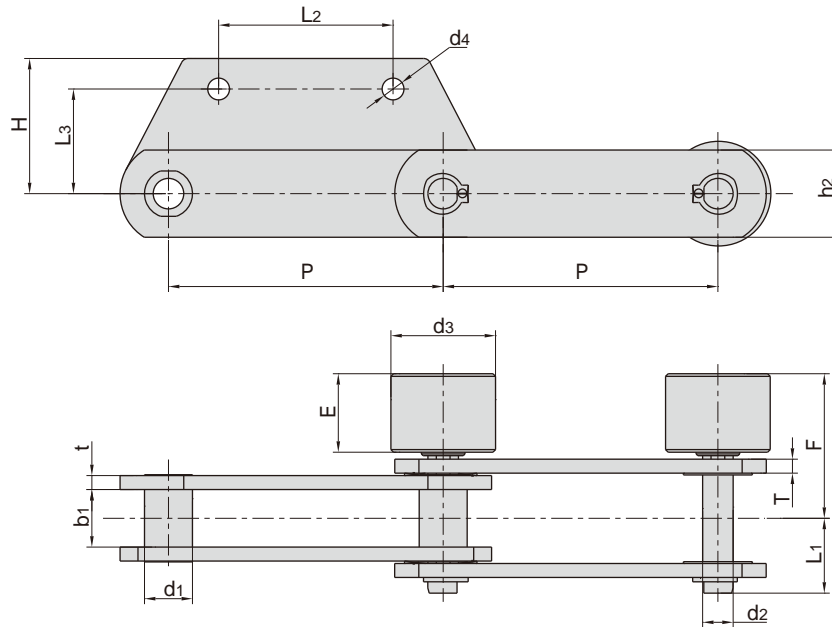

东华链号 Donghua Chain No.	节距 Pitch	滚子直径 Roller diameter	内节内宽 Width between inner plates	销轴直径 Pin diameter	销轴长度 Pin length	链板高度 Plate depth	链板厚度 Plate thickness	抗拉强度 Tensile strength	平均抗拉强度 Average tensile strength
	P	d1 max	b1 min	d2 max	L1 max	h2 max	t/T	Q min	Q0
	mm	mm	mm	mm	mm	mm	mm	kN/lbf	kN
P315F23	315.0	55.0	66.0	35.0	78.0	100.0	14.0	800/179840	880.0
P315F36	315.0	56.0	65.0	35.0	75.0	90.0	14.0	800/179840	880.0
P315F39	315.0	80.0	75.0	42.0	80.5	100.0	16.0/14.0	1100/24728	1210.0
P315F30SR1	315.0	55.0	60.0	30.0	63.5	90.0	12.0	630/141624	693.0
P400F14	400.0	63.0	90.0	40.0	92.5	100.0	16.0	1300/292240	1430.0
P400F15	400.0	75.0	130.0	50.0	120.5	130.0	18.0	1700/382160	1870.0
P500F8	500.0	70.0	124.0	50.0	118.8	120.0	16.0	1500/337200	1650.0

东华链号 Donghua Chain No.	H	L2	L3	d4	F	E	d3
	mm	mm	mm	mm	mm	mm	mm
P315F23	155.0	200.0	120.0	25.0	163.0	90.0	120.0
P315F36	155.0	280.0	120.0	25.0	163.0	90.0	120.0
P315F39	250.0	200.0	160.0	26.0	207.5	110.0	150.0
P315F30SR1	120.0	160.0	85.0	22.0	123.5	60.0	120.0
P400F14	155.0	300.0	115.0	25.0	168.0	70.0	120.0
P400F15	200.0	300.0	160.0	31.0	222.5	110.0	170.0
P500F8	155.0	400.0	120.0	26.0	217.3	110.0	150.0