

Special agricultural chains and attachments

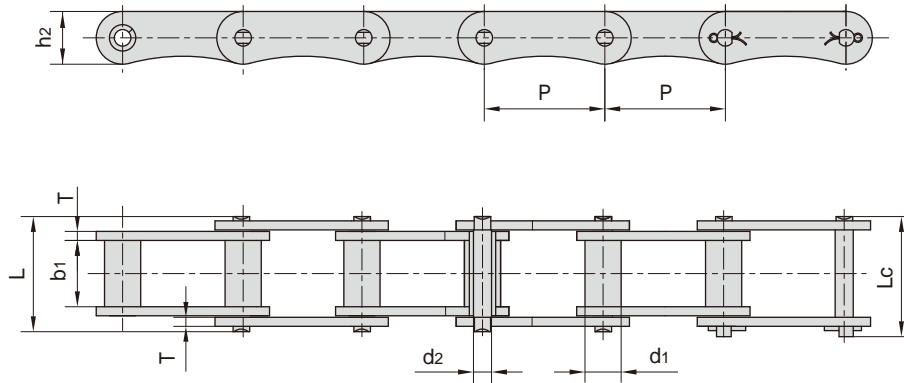

东华链号 Donghua Chain No.	节距	滚子直径	内节内宽	销轴直径	销轴长度		链板高度	链板厚度	抗拉强度	每米长重
	Pitch	Roller diameter	Width between inner plates	Pin diameter	Pin length		Plate depth	Plate thickness	Tensile strength	Weight per meter
	P	d1 max	b1 min	d2 max	L max	Lc max	h2 max	T max	Q min	q
	mm	mm	mm	mm	mm	mm	mm	mm	kN/lbf	kg/m
LV40	40	12.0	22.0	6.0	38.2	41.0	17.5	3.0	31.4/7136	1.53

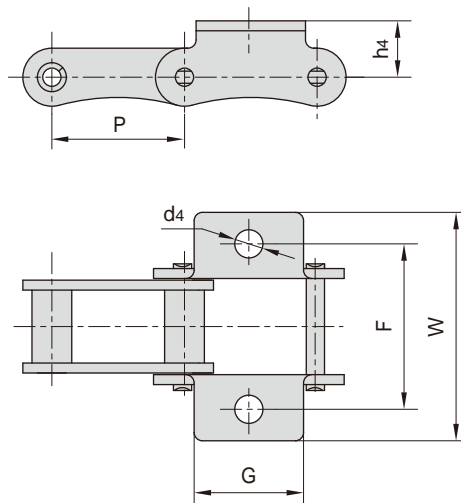

东华链号 Donghua Chain No.	P	G	F	W	h4	d4
	mm	mm	mm	mm	mm	mm
LV40K1	40.0	33.0	50.0	69.0	17.0	8.5

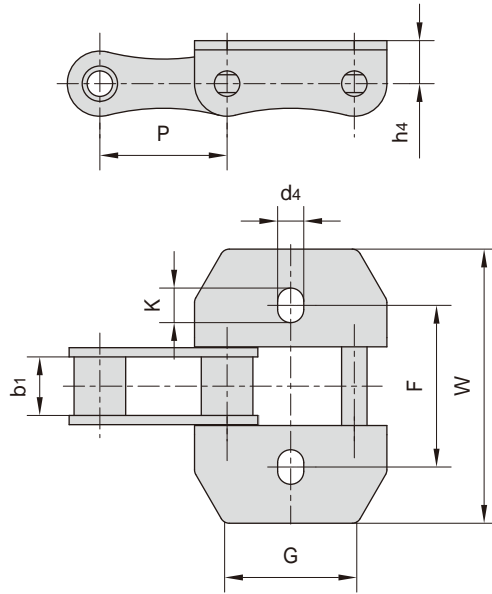

S1附件
S1 attachments

S2附件
S2 attachments

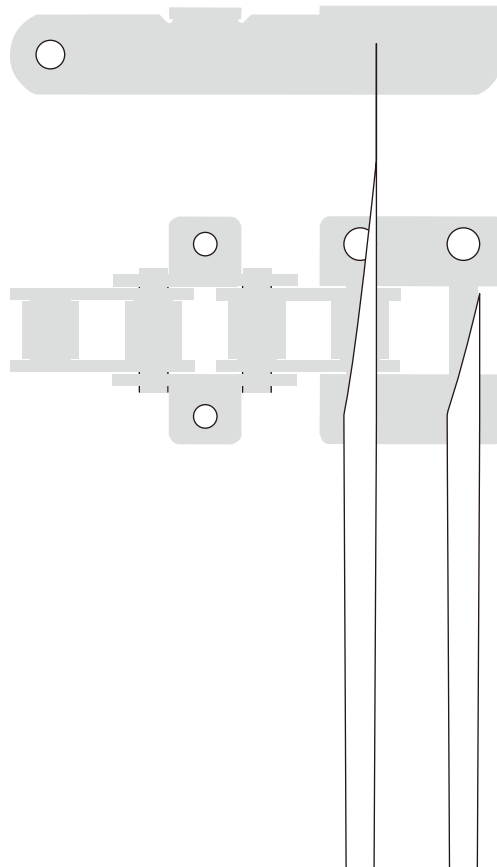

سنة

.

١٤٤٤